

FEATURES

- **Integrating Type Linear Heat Detector**
- **Analog Sensing**
- **Field Adjustable Alarm Set Point**
- **Three Cable Styles**
- **Restorable Up to 257°F (125°C)**
- **Short Circuit Discrimination**
- **Intrinsically Safe Option**
- **FM Approved, 30 ft. (9 m) Spacing**
- **CSFM Listed 7270-074:110**

DESCRIPTION

The AlarmLine™ Linear Heat Detector provides early detection of fire or overheating conditions by detecting changes in temperature in localized areas or over its entire length. It is especially suited for confined areas or harsh environments where adverse ambient conditions cause other detection devices to be unreliable or difficult to use. The system consists of two major components: a small diameter sensor cable and an interface module. The sensor cable is constructed with a negative temperature coefficient material, where a change in temperature results in an exponential decrease in resistance of the sensor. The interface module interprets this resistance change and provides an output to a control panel once the field programmable alarm set point is exceeded.

APPLICATIONS

- Open area protection
- Cable trays
- Rack storage
- Freezer warehouses
- Belt conveyers
- Floating roof fuel tanks
- Cooling towers
- Dust collectors
- Waste fuel drum storage
- Power distribution apparatus
- Escalators

BENEFITS

- **Flexible:**
 - Mechanical—Allows installation at point of risk.
 - Electrical—Compatible with all central control panels.
 - Alarm Levels—Adjustable for different temperatures.
- **Durable:**
 - Extrusion and Braiding options to satisfy environmental conditions and project risks.
- **Reliable:**
 - Fault signaling of open and short circuit conditions.
- **Recoverable:**
 - Self restoring after fire event to 257°F (125°C).
- **Sensitive:**
 - Proven superiority over point type measurement.



ANALOG HEAT SENSING

AlarmLine's analog heat sensing characteristics offer several distinct advantages:

- **Field adjustable:**
Alarm threshold may be alarm setpoint programmed to meet specific system requirements.
- **Restorable:**
Cable does not need to be replaced after an alarm event up to 257°F (125°C).
- **Integrating:**
It is not necessary to reduce sensor spacing with increased ceiling height per NFPA 72-1996, Section 5-2.4.1.2 Exception (a). System sensitivity remains constant as ceiling height increases without reducing the spacing.
- **Short circuit:**
The system will produce a discrimination trouble condition instead of a false alarm in the event of a conductor to conductor short due to damage or electrical faults.

SENSOR CABLE

The AlarmLine sensor cable consists of four 26 AWG copper conductors, each color-coded in an insulated sheath containing a negative temperature coefficient polymer. Two of the conductors are enameled, and provide loop continuity supervision, but not temperature sensing. The conductors are twisted at 30 turns per foot (90 per meter) and protected by a flame-retardant outer extrusion (see Figure 1). The color-coding of the four inner conductors is repetitively marked on the outer coating every 3 feet as an aid in installation. Cable is sold on standard rolls of 656 ft. (200 m).

Note: The maximum length of sensor cable per zone depends on the maximum ambient temperature defined on the nomogram. Regardless of ambient, however, the maximum length of cable is 3200 ft. (1000 m) per zone.

Sensor cable is available with the following part numbers:

- **Standard Sensor Cable, P/N 73-117068-013:**
Recommended for environments ranging from clean and dry to moderate dust and moisture.
- **Nylon Coated Sensor, P/N 73-117068-016:**
Recommended for use in wet, oily or corrosive environments or outdoors. Use in freezer warehouses.
- **Phosphor Bronze Braided Sensor, P/N 73-117068-019:**
Recommended for applications requiring superior abrasion protection or increased tensile strength.

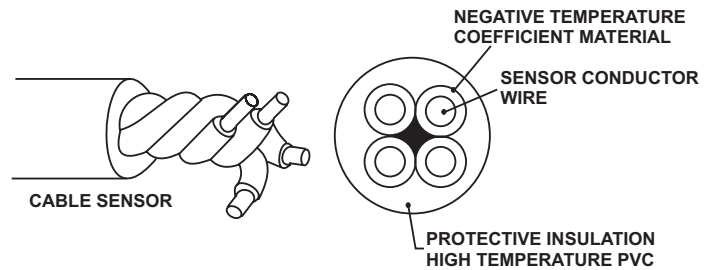

Figure 1. Standard Sensor Cable

INTERFACE MODULE

The interface module is available in two versions: a two-wire version for use with Kidde control panels and a 4-wire version for use with any 24 Vdc control panel. The 4-wire version is powered by an external 24 Vdc source and is connected to a fire alarm control panel's detection input circuit via alarm and trouble relay contacts. The interface module monitors the resistance of the sensor cable, and generates an alarm whenever the resistance drops below the preset threshold. The module also supervises the sensor cable for opens and shorts to generate a fault condition. These conditions are displayed on the module faceplate by the two LED indicators: FIRE is the red LED and FAULT is the yellow LED.

Module part numbers are:

- 73-117068-046:
4-Wire interface module, in gray polycarbonate enclosure. Provides alarm and trouble relay contacts.
- 73-117068-042:
2-Wire interface module circuit board.
- 73-117068-044:
Gray polycarbonate enclosure only.
6.625 in. (168 mm) H x 4.125 in. (105 mm) D.

CABLE SPECIFICATIONS

Description	Standard Sensor	Nylon Coated Sensor	Bronze Braided Sensor
Part Number	73-117068-013	73-117068-016	73-117068-019
Jacket Construction	Blue PVC	Black nylon extrusion over blue PVC	Phosphor bronze braid over blue PVC
Standard Available Length	656 ft. (200 m) reel	656 ft. (200 m) reel	656 ft. (200 m) reel
External Diameter	0.117 in. (3.25 mm)	0.153 in. (4.25 mm)	0.153 in. (4.25 mm)
Weight per 656 ft. (200 m)	7 lb. (3.2 kg)	9.5 lb. (4.3 kg)	18.3 lb. (8.3 kg)
Tensile Strength	100 N	100 N	1000 N
Conductor Insulation Colors	1 = Orange 2 = White 3 = Red 4 = Blue	1 = Orange 2 = White 3 = Red 4 = Blue	1 = Orange 2 = White 3 = Red 4 = Blue
Conductor Material	26 AWG Solid Copper	26 AWG Solid Copper	26 AWG Solid Copper
Conductor Diameter	0.018 in. (0.460 mm)	0.018 in. (0.460 mm)	0.018 in. (0.460 mm)
Twist of Inner Conductors	30 per ft. (90 per m)	30 per ft. (90 per m)	30 per ft. (90 per m)
Dielectric Material	Specially Doped Polymer	Specially Doped Polymer	Specially Doped Polymer
Standard Outer Jacket Material	High Temperature PVC	High Temperature PVC	High Temperature PVC
Voltage Proof Between PVC Jacket and a Conductor	10 KV	10 KV	10 KV
Service Life	Up to 212°F (100°C) = 30 Years @ 257°F (125°C) = 24 Hours. Self Restores below 257°F (125°C) Above 374°F (190°C) is the destructive temperature.	Up to 212°F (100°C) = 30 Years @ 257°F (125°C) = 24 Hours. Self Restores below 257°F (125°C) Above 374°F (190°C) is the destructive temperature.	Up to 212°F (100°C) = 30 Years @ 257°F (125°C) = 24 Hours. Self Restores below 257°F (125°C) Above 374°F (190°C) is the destructive temperature.
Maximum Spacing Between Parallel Runs	30 ft. (9 m)	30 ft. (9 m)	30 ft. (9 m)

SENSOR MOUNTING HARDWARE

Three types of standard mounting hardware (master clamp, flange clamp, nylon cable tie) for AlarmLine permit safe, secure sensor cable installation in most applications. Other mounting means may be used as required by the specific application. The sensor should be supported at a minimum of ten foot intervals on straight runs when under tension, and more as conditions dictate at corners and transition points to provide suitable strain relief. Local codes or conditions may also require the sensor cable to be supported at closer intervals. Refer to Manual MC-428 for specific mounting information.

MODULE SPECIFICATIONS

Specification	2-Wire Version	4-Wire Version
Supply Voltage	+8 to 30 Vdc	+17 to 30 Vdc
Current Consumption, Standby	40 to 60 μ A	50 to 70 μ A
Current Consumption, Alarm	53 mA	82 mA
Current Consumption, Fault	110 to 150 μ A	16 mA
Noise Performance	Withstands 5% RMS 60 Hz supply noise or 1 V RMS 60 Hz sensor noise with negligible performance change. RFI immunity at 10V/meter field strength over the band of 20 to 900 MHz	
Visual Indicators	Fire: Panel mounted continuous red LED. Fault: Panel mounted flashing yellow LED.	
Controls	Test Switch: Fault and Fire positions. Verifies module operations in both modes. Fire Trip Selection: 12 position precalibrated switch to select alarm threshold.	
Relay Outputs	None	Fire Alarm: Form C relay rated 2A @ 30 Vdc. Energizes on alarm. Fault: Form C relay rated 2A @ 30 Vdc. Energizes on trouble.
Auxiliary Outputs	Fire Alarm: Terminals for connection of remote alarm LED. Fault: Normally closed transistor output	
Operating Temperature Range	-13°F to +125°F (-25°C to +50°C)	

INTRINSIC SAFETY BARRIERS

In classified hazardous areas where potentially explosive vapors, dust or fibers exist, AlarmLine cable must be installed using an intrinsic safety barrier. Barrier P/N 73-117068-031 is a shunt-diode safety barrier which limits the current and voltage in the sensor cable to safe levels. Each barrier handles two conductors, so two barriers are needed for each sensor cable. The barriers are designed to mount in separate weathertight enclosures. The intrinsic safety barrier specifications are as follows:

FM Approvals	Class I, Division 1, Groups A, B, C, D Class II, Division 1, Groups E, F, G Class III, Division 1
Operating Temperature	-4° F (-20° C) to 140° F (60° C)

SETTING THE ALARM TEMPERATURE

The alarm temperature and the correct position of the 12-position alarm trip switch on the interface module are determined by use of the AlarmLine nomogram. The use of the nomogram requires two known factors:

- Maximum ambient temperature of the alarm zone (Scale A).
- The total length of the sensor cable to be used (Scale L).

The resistance change required to create an alarm can be a result of either a predetermined minimal increase in temperature over the entire length of the sensor, or a significant increase on a shorter section of cable. This integrating (averaging) effect of the sensor cable allows it to detect a localized hot spot or a low level temperature increase over its entire length. The alarm temperature in either case is determined only after the alarm trip switch position is determined.

A shorter section of sensor cable exposed to an overheat condition will require a higher temperature to achieve an alarm than a longer length of sensor cable exposed to the same overheat condition. Refer to Manual MC-428 for further programming information.

EXAMPLE:

A 500 ft. (152 m) length of AlarmLine type "T" sensor cable is required to operate in a space with a maximum ambient temperature of 115°F (46°C).

METHOD:

1. In Figure 2, a straight line is drawn from the 500 ft. (152 m) mark on Scale L through the 115°F (46°C) mark on Scale A. The line crosses Scale S at approximately switch position 7.
2. In Figure 3, a straight line is drawn from the alarm trip switch position 7 on Scale S to the 500 ft. (152 m) sensor cable length on Scale A.

SOLUTION:

1. The AlarmLine linear heat detector in this example will operate in an ambient temperature up to about 115°F (46°C) and not generate a false alarm. See Scale A in Figure 3.
2. The AlarmLine Linear Heat Detector in this example will generate an alarm if the temperature of the entire sensor length averages about 132°F (56°C) as shown where the line crosses Scale T in Figure 3. Higher temperatures would be needed to initiate an alarm over shorter sections of entire sensor length.
3. Alarm temperatures for shorter sections of the AlarmLine Linear Heat Detector in this example with 500 ft. (152 m) of sensor and the alarm trip switch set to position 7 may also be calculated. On Figure 3, draw straight lines from position 7 on Scale S to any desired length less than 500 ft. (152 m) on Scale L. According to the above example:
 - 500 ft. (152 m) at 132°F (56°C) will cause an alarm.
 - 130 ft. (40 m) at 160°F (71°C) will cause an alarm.
 - 20 ft. (6 m) at 195°F (91°C) will cause an alarm.
 - 10 ft. (3 m) at 208°F (98°C) will cause an alarm.

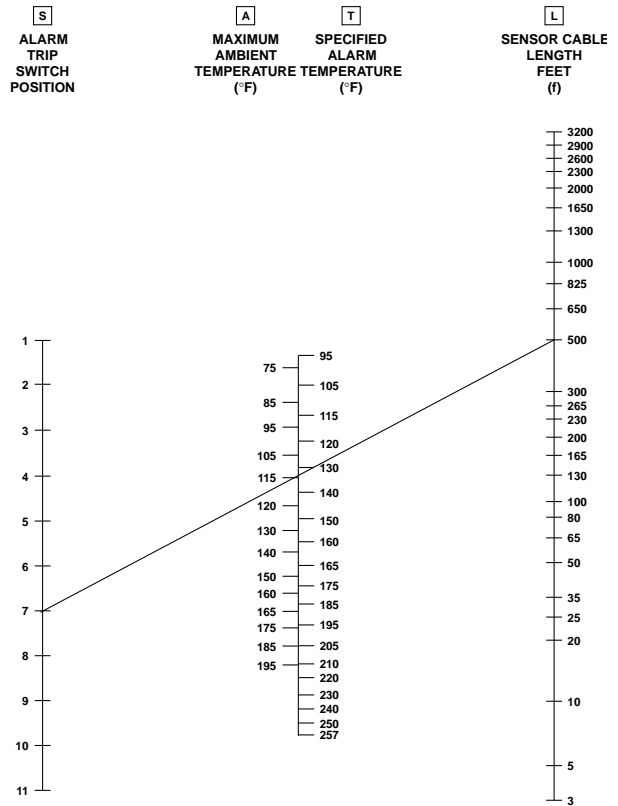

Figure 2. Example for Type "T" Cable

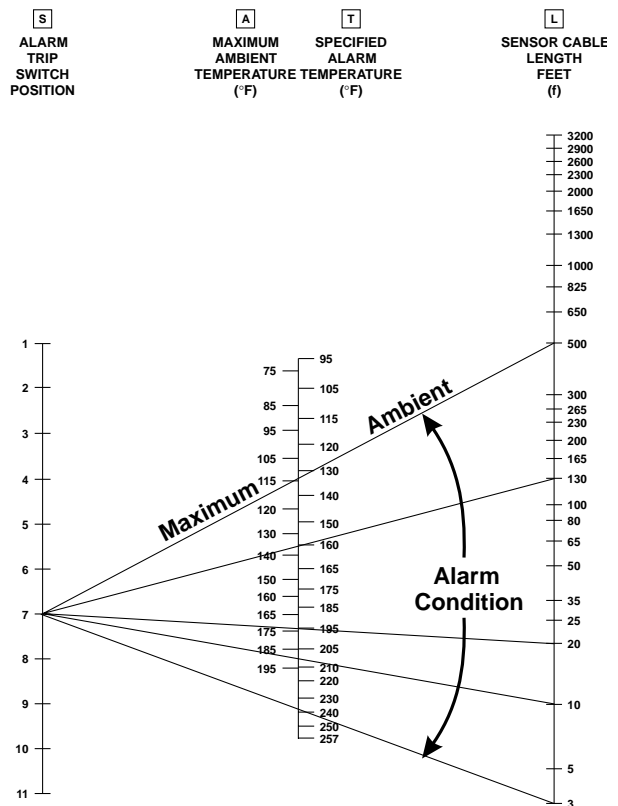

Figure 3. Example for Type "T" Cable

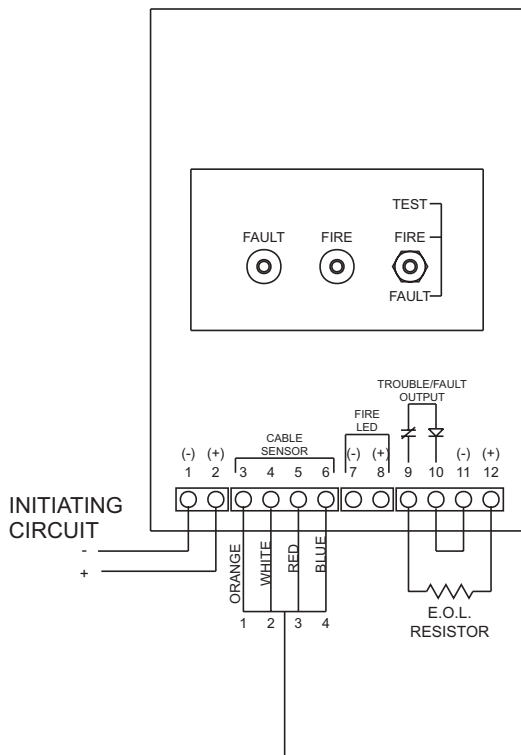

Figure 4. 2-Wire Module Wiring Diagram

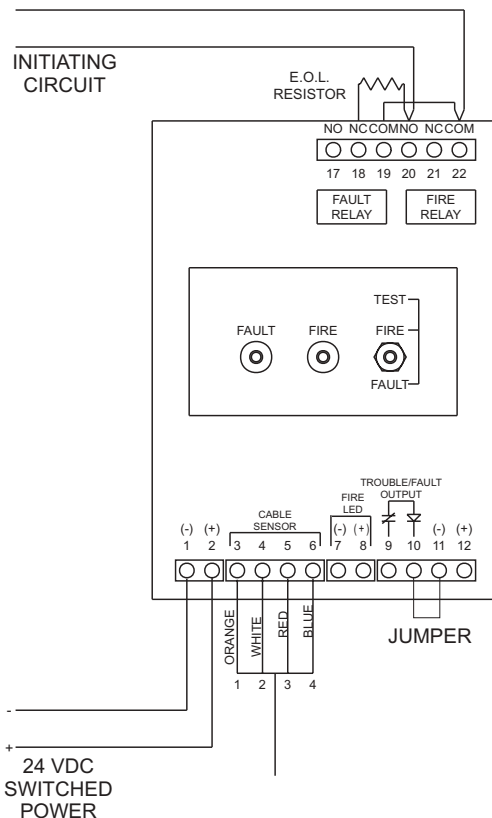

Figure 5. 4-Wire Module Wiring Diagram

INTERFACE MODULE WIRING

The 2-wire interface module, P/N 73-117068-042, may be connected to a Scorpio or Gemini fire control panel. The module is wired directly to the initiating circuit of the panel as shown in Figure 4. When remote mounting, enclosure (P/N 73-117068-044) must be purchased separately from the 2-wire module.

The 4-wire interface module, P/N 73-117068-046, may be connected to any control panel. The control panel must have a 24 Vdc switched power output which is interrupted when the control panel is reset. The module's alarm and fault relays are wired as shown in Figure 5. This interface module comes pre-mounted in a P/N 73-117068-044 enclosure, and is designed to be mounted outside the control panel.

Up to 6,000 feet of 4 conductor 16 AWG lead-in wire may be connected between the module and the beginning of the sensor. The end of the sensor cable is terminated with the orange and white, and red and blue conductors spliced together. Refer to Manual MC-428 for complete wiring information.

SENSOR CABLE HEAT PAD

AlarmLine sensor cable heat pads (P/N 73-117068-041) are used in critical areas. The heat pad concentrates the sensor into a compact area, thus enabling it to quickly detect localized overheating at a lower temperature, because a greater length of cable is heated at the same time. Heat pads can also be used at the end of a zone to accommodate testing of the sensor with a hot air gun.

MODULE TEST FEATURE

A three position Alarm-Normal-Fault test switch allows the user to perform a simple electronic test of the interface module's electronic circuitry. Before testing, care should be taken to disarm any alarm functions since the fire and fault tests will be signaled to the control panel as genuine alarm and fault conditions.

ARCHITECT/ENGINEERING SPECIFICATIONS

- The Linear Heat Detector shall be Kidde AlarmLine P/N 73-117068-013 [or -016 or -019] or equal in quality, features and performance as described.
- The linear heat detector shall be of the integrating (averaging) type and consist of four small gauge solid copper conductors each insulated with a negative temperature coefficient material. The conductors shall be twisted at a rate of approximately 30 turns per foot (90 per meter) to cancel out potential high voltage inductance. The conductor insulation shall be color coded for ease of installation. The sensor cable shall have an outer protective extrusion of high temperature PVC material.
Option A for -016 sensor: The sensor cable shall have an additional outer extrusion of nylon as additional protection against harsh environments.
Option B for -019 sensor: The sensor cable shall have an outer braid of Phosphor Bronze to increase its tensile strength and for protection against abrasion.
- The linear heat detector shall have a field adjustable alarm set-point.
- The sensor cable shall be self-restorable to its normal condition after an alarm up to 257°F (125°C).
- The sensor cable shall be capable of being spliced in the field.
- The sensor shall have Factory Mutual recommended spacing requirements of 30 ft. (9 m), regardless of the height.

ORDERING INFORMATION

Description	Part Number
Standard PVC Sensor Cable 656 ft. (200 m) Coil	73-117068-013
Nylon Coated Sensor Cable 656 ft. (200 m) Coil	73-117068-016
Bronze Braided Sensor Cable 656 ft. (200 m) Coil	73-117068-019
4-wire Interface Module with Relay Output and Surface Mount Enclosure	73-117068-046
2-wire Interface Module circuit board only	73-117068-042
Surface Mount Enclosure only, for Interface Module circuit board	73-117068-044
Nylon Cable Tie (pkg. 100) for pipe up to 8"	73-117068-020
Master Clamp (pkg.100) for flanges to 1/2"	73-117068-022
Flange Clip (pkg. 100) for flanges to 3/16"	73-117068-023
Flange Clip (pkg. 100) for flanges to 1/4"	73-117068-024
Nylon Cable Clamp (pkg.100) for use with Master Clamp or Flange Clips or Nylon Cable Tie	73-117068-025
Weathertight Connector, used with Standard Sensor	73-117068-026
Weathertight Connector, used with Nylon Coated or Bronze Braided Sensor	73-117068-027
In-Line Sensor Splice (pkg.10) 4 required per splice	73-117068-028
In-Line Sensor Splice Crimping Tool	73-117068-029
Sensor Termination Kit (pkg.10) - terminates 10 zones	73-117068-030
Intrinsic Safety Barrier (2 required per zone)	73-117068-031
Intrinsic Safety Barrier Weathertight Enclosure holds (2) Barriers	73-117068-032
Intrinsic Safety Barrier Weathertight Enclosure holds up to (5) Barriers	73-117068-033
Intrinsic Safety Barrier Weathertight Enclosure holds up to (12) Barriers	73-117068-034
Intrinsic Safety Barrier Weathertight Enclosure holds up to (24) Barriers	73-117068-035
Intrinsic Safety Barrier Weathertight Enclosure holds up to (32) Barriers	73-117068-036
AlarmLine™ Installation Manual and Application Guide	MC-428

Kidde is a registered trademark of Kidde-Fenwal, Inc.
AlarmLine and Scorpio are trademarks of Kidde-Fenwal, Inc.

This literature is provided for informational purposes only. KIDDE-FENWAL, INC. assumes no responsibility for the product's suitability for a particular application. The product must be properly applied to work correctly.
If you need more information on this product, or if you have a particular problem or question, contact KIDDE-FENWAL INC., Ashland, MA 01721. Telephone: (508) 881-2000.



400 Main Street
Ashland, MA 01721
Ph: (508) 881-2000
Fax: (508) 881-8920
<http://www.kiddefiresystems.com>